

# **Aviation Spectrum Resources, Inc. Selective Calling (SELCAL) Users Guide**



**180 Admiral Cochrane Drive, Suite 300  
Annapolis, MD  
21401-7435  
U.S.A.**

**Please review instructions inside for additional copies,  
obtaining updates, and checking the currency of this  
document.**



# **Aviation Spectrum Resources, Inc. Selective Calling (SELCAL) Users Guide**



**180 Admiral Cochrane Drive, Suite 300  
Annapolis, MD  
21401-7435  
U.S.A.**

**Please review instructions inside for additional copies,  
obtaining updates, and checking the currency of this  
document.**

<i>Change Log</i>		
<i>Date</i>	<i>Rev</i>	<i>Action/Preparer</i>
13 January 2010	–	Original Issue R. Stutz
12 August 2010	A	R. Stutz
14 September 2011	B	Added SELCAL Ordering Process N. Taylor
2 April 2018	C	Updated contact details A. Roy
9 April 2019	D	Removed Section 5 and all references to Section 5 C. Wheatley
10 September 2024	E	Added SELCAL 32 information Z. Baton

**The aircraft operating agency is responsible for notifying ASRI if any of the following occur:**

- a. The aircraft is retired, sold, destroyed, or returned to leasing/holding company**
- b. The registrant’s mailing address changes**
- c. Aircraft registration/tail number changes**
- d. Aircraft communications links change (HF and /or VHF)**
- e. Aircraft type of code supported changes (12-tone/16-tone/32-tone)**
- f. Areas of operation for an aircraft change**

**Note: Whenever the ASRI Selective Calling (SELCAL) Users Guide is revised, a copy of the current manual will also be posted on the ASRI web site ([www.asri.aero](http://www.asri.aero)) for customers to verify that the manual they have is the current edition and also so that they may download copies, as needed. It is posted on the main page under "Manuals."**

## SELCAL Requirements Summary

The following items should be considered if an organization plans to implement SELCAL:

1. Has the following information been provided to ASRI to obtain SELCAL codes:
  - a. Company name and address
  - b. Name of point of contact including telephone and email information
  - c. Number of SELCAL codes requested
  - d. Aircraft registration/tail numbers
  - e. Aircraft communications links available per aircraft (HF and /or VHF)
  - f. Type of code supported per aircraft (12-tone/16-tone/32-tone)
  - g. Areas of operation per aircraft (See table 4-1)
2. Has the SELCAL codes obtained from ASRI been correctly placarded in the cockpit of each of the operating agency aircraft?
3. Have flight crews and dispatch personnel been properly trained on ICAO SELCAL procedures specifically including the following:
  - a. Procedures for preflight checks?
  - b. Procedures for establishment of communications?
  - c. En-route procedures?
4. Has a current copy of the ASRI Users Guide been provided to flight crews and dispatch personnel?
5. Has the aircraft operating agency ensured that all aeronautical (ground) stations with which the aircraft would normally communicate during a particular flight know the SELCAL code associated with the radiotelephony call sign?
6. Has the aircraft operating agency disseminated to all aeronautical stations concerned, at regular intervals, a list of SELCAL codes assigned to its aircraft or flights?
7. Did the aircraft flight crew:
  - a. Include the SELCAL code in the flight plan submitted to the appropriate air traffic services unit?
  - b. Ensure that the HF aeronautical station has the correct SELCAL code information by establishing communications temporarily with the HF aeronautical station while still within VHF coverage?
8. For the SELCAL system to operate properly, is the aircraft operating on the same HF or VHF frequency as the aeronautical stations?
9. The aircraft operating agency is responsible for notifying ASRI if any of the following occur:
  - a. The aircraft is retired, sold, destroyed, or returned to leasing/holding company
  - b. The registrant's mailing address changes
  - c. Aircraft registration/tail number changes
  - d. Aircraft communications links change (HF and /or VHF)
  - e. Aircraft type of code supported changes (12-tone/16-tone/32-tone)
  - f. Areas of operation for an aircraft change

**Note: Due to the limited number of SELCAL codes, the same code assignments to multiple aircraft should be expected. Therefore, the use of correct radiotelephony procedures is emphasized when establishing communications via SELCAL.**

**Table of Contents**

**1 SCOPE ..... 1-1**

1.1 INTRODUCTION ..... 1-1

1.2 APPLICABLE DOCUMENTS..... 1-2

1.3 TERMS AND ACRONYMS ..... 1-2

**2 SYSTEM DESCRIPTION ..... 2-1**

2.1 FUNCTION ..... 2-1

2.2 COMPONENTS ..... 2-1

2.3 PRINCIPLES OF OPERATION ..... 2-1

2.4 SELCAL CODES ..... 2-3

**3 PROCEDURES AND REGULATORY ..... 3-1**

3.1 PROCEDURES FOR NOTIFICATION TO AERONAUTICAL STATIONS OF SELCAL CODES..... 3-1

3.2 PROCEDURES FOR PREFLIGHT CHECK ..... 3-2

3.3 PROCEDURES FOR ESTABLISHMENT OF COMMUNICATIONS ..... 3-2

3.4 EN-ROUTE PROCEDURES ..... 3-2

3.5 SELCAL CODE ASSIGNMENTS TO AIRCRAFT..... 3-3

**4 SYSTEM ADMINISTRATION..... 4-1**

**List of Tables**

TABLE: 2-1 SELCAL TONES ..... 2-5

TABLE: 4-1 SELCAL AREAS OF OPERATION ..... 4-2

**List of Figures**

FIGURE: 2-1 SELCAL SYSTEM BLOCK DIAGRAM..... 2-2

FIGURE: 2-2 SELCAL CODE AC-BD EXAMPLE..... 2-6





# 1 Scope

---

## 1.1 Introduction

A state-of-the-art-technology when it was introduced for use in civil aviation in 1957, the Selective Calling (SELCAL) system permits selective calling of individual aircraft over the aeronautical mobile voice channels. It can be used on high frequency (HF) or very high frequency (VHF) channels and is designed to relieve flight crews from the need to continuously maintain a listening watch on their assigned radio channels. This generates a number of benefits including reduced flight crew workload and cockpit noise both of which can have a negative effect on human performance.

In order to uniquely identify individual aircraft using the SELCAL system, SELCAL codes were assigned to each aircraft. SELCAL code assignments were coordinated worldwide, on behalf of the International Civil Aviation Organization (ICAO), by Aeronautical Radio, Inc. (ARINC), which until recently had served as the registrar of the system since it was first introduced in 1958 for use by civil aviation. ICAO and ARINC managements agreed to work together without a formalized agreement. ARINC was responsible for accepting all applications from outside organizations interested in obtaining SELCAL assignments and for issuing SELCAL codes. ARINC would periodically coordinate with ICAO on the number of actual code assignments that were made to applicants and total number of users of the system.

In order for ARINC to proceed with obtaining outside financial support, ARINC petitioned the Federal Communications Commission (FCC) in September 2004 with a request for Declaratory Ruling that would alter the manner in which VHF and HF spectrum used in aeronautical en-route service was managed. This request would not only allow the change in spectrum management but would also enable the restructuring of ARINC. In March 2005, the FCC granted ARINC's request to move to a new entity under aviation industry governance and control the management of VHF and HF frequency spectrum used to provide the aeronautical en-route service in accordance with Part 87 of the FCC rules that was currently licensed to ARINC. The ARINC Board of Directors asked Management to proceed with creating a new entity. As a result, on January 1, 2006, Aviation Spectrum Resources, Inc (ASRI) was organized and incorporated within the State of Delaware. A separate ASRI Board of Directors consisting of airline management staff was formed to provide guidance and oversight to the new company.

In January 2006 ASRI replaced ARINC as the registrar of the SELCAL system for the aviation community. ASRI, instead of ARINC, is now responsible for administering SELCAL codes, maintaining the database, and providing periodic reports on the status of the SELCAL system to ICAO.

## 1.2 Applicable Documents

- AEEC
  - ARINC Characteristic 596-4 Mark 2 Airborne SELCAL System
  - ARINC Characteristic 714-6 Mark 3 Airborne SELCAL System
- RTCA
  - DO-93 Minimum Performance Standard – Airborne Selective Calling Equipment
- ICAO
  - Annex 10 - Aeronautical Telecommunications Volume II – Communication Procedures including those with PANS status
- FAA
  - TSO-C59a Airborne Selective Calling (SELCAL) Equipment
- North Atlantic Programme Coordination Office (NAT PCO)
  - Sample Oceanic Checklist
- ASRI
  - Aeronautical Frequency Committee (AFC) Manual

## 1.3 Terms and Acronyms

**Aeronautical Station:** A ground station equipped to engage in radio communications or to effect radio transmission of energy. Air Navigation Service Providers (i.e. FAA) operate ground stations that communicate with aircraft stations for the purposes of air navigation.

**Air Navigation Service Providers (ANSP):** An organization that separates aircraft on the ground or in flight in a dedicated block of airspace on behalf of a state or a number of states. ANSPs are either government departments; state owned companies, or privatized organizations.

**Aircraft Station:** A radio station on board any aircraft: includes all radio-transmitting devices operating in the Aviation Radio Services.

**ASRI Headquarters:** The principal office of ASRI, 180 Admiral Cochrane Drive, Suite 300, Annapolis, MD, 21401. The principal office number for ground station service users to contact is (410) 266-6030. Email is [info@asri.aero](mailto:info@asri.aero).

**Aviation Radio Service:** The aviation radio service is an internationally-allocated radio service providing for safety of life and property in air navigation. There are two types of aviation radio services:

Aircraft Radio Stations are stations in the aeronautical mobile service that use radio equipment, such as two-way radiotelephones, radar, radionavigation equipment, and Emergency Locator Transmitters (ELTs), on board aircraft for the primary purpose of ensuring safety of aircraft in flight.

Ground Radio Stations are usually two types. The Aeronautical and Fixed Service includes stations used for ground-to-air communications with aircraft about aviation safety, navigation, or preparation for flight. The Aeronautical Radionavigation Service is made up of stations used for navigation, obstruction warning, instrument landing, and measurement of altitude and range.

**Ground Station:** A station equipped to engage in radio communications or to effect radio transmission of energy.

**Listening Watch:** Flight crew responsibility to continuously monitor a radio using headsets or cockpit speaker for the purpose of receiving radio communications from an aeronautical station.

**Radio Call Sign:** The aircraft registration/tail number (N-number for US registered aircraft assigned to the aircraft by the FAA) or flight number (airline abbreviation followed by the flight service number). An example of a flight number for Delta Airlines flight 123 would be DAL123.

**Radio Telephony Designator:** A one or two word designator, normally the company name or an abbreviation thereof, but may not be, that is used in combination with the flight number to become the flight identification in all voice communications with air traffic control. Examples: American Airlines flight 156 is AAL156 and “American 156” or US Airways Flight 347 is USA347 and “Cactus 347”.

The following abbreviations, acronyms, and mnemonics are used in this document:

<i>Item</i>	<i>Meaning</i>
AEEC	Airline Electronic Engineering Committee
AF	Africa
AFC	Aeronautical Frequency Committee
ARINC	Aeronautical Radio, Inc.
ASRI	Aviation Spectrum Resources Inc.
ATS	Air Traffic Services
CA	Central America
ELT	Emergency Locator Transmitters
EU	Europe
FAA	Federal Aviation Administration
FCC	Federal Communication Commission
HA	Hawaii
HF	High Frequency.
Hz	Hertz
ICAO	International Civil Aviation Organization
ME	Middle East
NA	North America
NF	North Africa
NAT PCO	North Atlantic Programme Coordination Office
RTCA	Radio Technical Commission for Aeronautics
SA	South America
SE	South East Asia

<i>Item</i>	<i>Meaning</i>
SELCAL	Selective Calling System
SF	South Africa
SP	South Pacific
UN	United Nations
VHF	Very High Frequency
WP	West Pacific



# 2 System Description

---

## 2.1 Function

The Selective Calling System known as SELCAL is a signaling method to alert an individual aircraft that a ground station wishes to communicate with the aircraft. SELCAL signals are capable of being transmitted on en-route frequencies with existing HF or VHF ground-to-air communication transmitters and receivers. A SELCAL transmission consists of a combination of four pre-selected audio tones whose transmission requires approximately two seconds. The normal functioning of the ground-to-air communications link should be unaffected, except at such time as the selective calling function is being performed.

## 2.2 Components

The elements comprising the overall system are the following:

- Ground SELCAL tone generator and control panel
- Ground-to-air transmitter, HF or VHF
- Airborne receiver, HF or VHF
- Airborne SELCAL decoder unit
- Aircraft SELCAL signal indicators

A block diagram of the selective calling system is shown in Figure 2-1.

## 2.3 Principles of Operation

With the selective calling system, the normal voice calling method is replaced with the transmission of coded tones to the aircraft over the voice communications channel. **It is critical to remember that both the ground station and the aircraft need to be operating on the same HF or VHF frequency for the system to operate properly.**

When the ground operator desires to call a particular aircraft, the SELCAL code assigned to that aircraft is keyed into the tone generator. The tone pulses that are generated in the ground station tone generator are transmitted to the aircraft via the ground-to-air transmitter. A single selective call consists of a combination of four pre-selected audio tones whose transmission requires approximately two seconds. The tones are received by the aircraft receiver and presented to the decoder connected to the audio output of the receiver. The airborne receiver and decoder equipment is capable of receiving and interpreting the correct code and

rejecting all other codes in the presence of random noise and interference. Receipt of the assigned tone code (SELCAL code) activates a cockpit call system for display on the signal indicator.

The type of signal indicator can be chosen to suit operational requirements of the user and may consist of a lamp, a bell, a chime or any combination of such indicating devices. On aircraft equipped with SELCAL the flight crew has the capability to also maintain a conventional listening watch, using headsets or cockpit speaker.

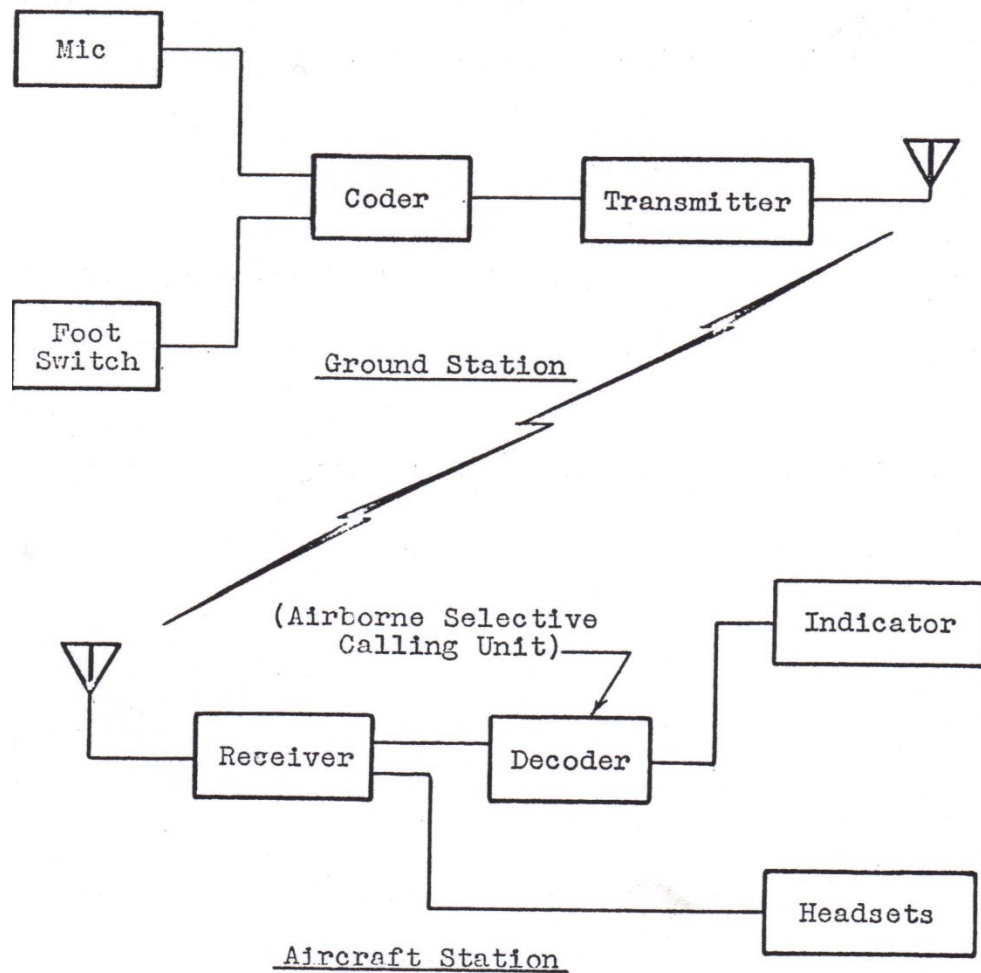

Figure: 2-1 SELCAL System Block Diagram



## 2.4 SELCAL Codes

The SELCAL system was initially based on 12-tone codes which provided for a total of 2,970 individual code assignments. In the early 1980s, the registrar encountered a growth problem when the requests for code assignments from the aircraft operators exceeded the number of unassigned codes available. To address the problem, the inventory of available codes was increased by adding four more tones. This provided for another 7,950 code assignments, a solution that became applicable when provisions for the 16-tone code system were introduced in ICAO Annex 10 in 1985.

Although the combined total number of SELCAL code assignments, based on the earlier 12-tone system and the subsequent introduction of the 16-tone system, which provided a total of 10,920 assignments, the inventory of unused codes eventually became exhausted. To continue to meet the requirements for new assignments, it was necessary for the registrar to assign duplicate codes. Flight crews, for example, can anticipate that they will receive a greater number of SELCAL activations for messages intended for other aircraft, a situation that raises the possibility of misdirected messages. The problems associated with this practice can be expected to increase over time. To remediate the concern of duplicate SELCAL assignments, 32-tone codes were introduced on November 3, 2022. This installation has resulted in the addition of up to 200,000 new unique SELCAL codes being available for assignment.

The registrar makes every effort to reduce the possibility of conflict caused by duplicate code assignments. The first and principal means is to attempt to maintain an adequate geographical separation between the aircraft assigned duplicate codes. However, this is not always possible, and aircraft with worldwide code assignments will occasionally operate simultaneously in the same airspace.

**In the current circumstances, it is essential that aircrews and air traffic service (ATS) personnel remain vigilant and recognize that SELCAL can only be reliable when good radiotelephony procedures are also practiced. What is needed to ensure communications integrity is a consistent application of fundamental radiotelephony procedures. It is important, for example, that an aircraft responding to a SELCAL message reply with its full communication radio call sign.**

The four tones required for a single SELCAL code assignment are selected from a total of thirty-two tones available in the ground station SELCAL installation. For convenient reference, the thirty-two tones are designated by letters of the alphabet ("A" through "Z"; with "I", "N", and "O" omitted) as well as with numerical characters (1-9). Tones "P", "Q", "R", and "S" were the four tones that were added to the existing 12 tones in 1985. Which was then followed by the addition of T-Z and 1-9 in 2022, to bring the total number of tones from 16 tones to 32 tones.

Each SELCAL equipped aircraft is assigned a permanent four-character code. The code is placarded in the cockpit of each SELCAL equipped aircraft. See Table 2-1 for tones being used in the SELCAL system.

<b>DESIGNATION</b>	<b>FREQUENCY (Hz)</b>	<b>DESIGNATION</b>	<b>FREQUENCY (Hz)</b>
A	312.6	T	329.2
B	346.7	U	365.2
C	384.6	V	405.0
D	426.6	W	449.3
E	473.2	X	498.3
F	524.8	Y	552.7
G	582.1	Z	613.1
H	645.7	1	680.0
J	716.1	2	754.2
K	794.3	3	836.6
L	881.0	4	927.9
M	977.2	5	1029.2
P	1083.9	6	1141.6
Q	1202.3	7	1266.2
R	1333.5	8	1404.4
S	1479.1	9	1557.8

*Table: 2-1 SELCAL Tones*

Tone codes are made up of the various combinations of the tones as seen in Table 2-1 and are designated by both alphabetic and numeric characters. An example of a SELCAL code would be AC-BD. Each transmitted code should be made up of two consecutive tone pulses, with each pulse containing two simultaneously transmitted tones. The pulses should be of 1.0 plus or minus 0.25 seconds duration, separated by an interval of 0.2 plus or minus 0.1 second. See Figure 2-2 for the transmission sequence of SELCAL Code example of AC-BD.

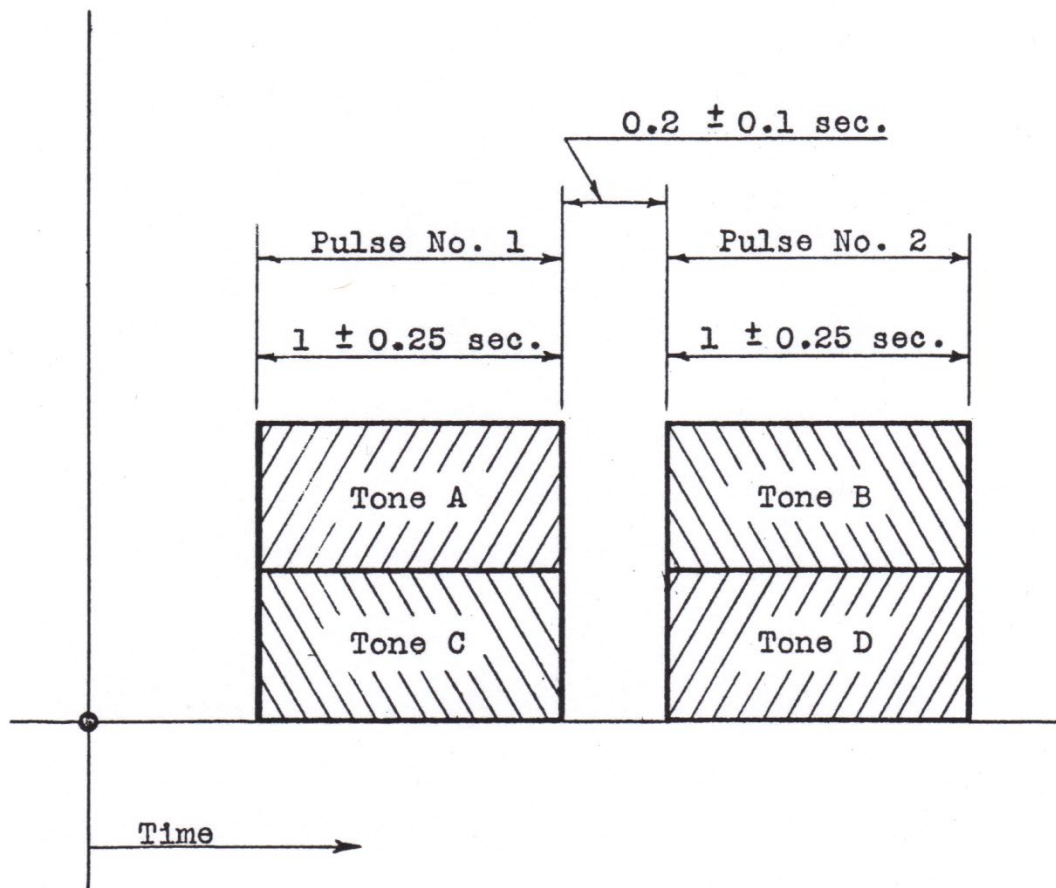

Figure: 2-2 SELCAL Code AC-BD Example

# 3 Procedures and Regulatory

---

The International Civil Aviation Organization (ICAO), a United Nations (UN) Specialized Agency, is the global forum for civil aviation. ICAO works to achieve its vision of a safe, secure, and sustainable development of civil aviation through cooperation through its member States. ICAO is responsible for defining air navigation policies and procedures for the civil aviation industry.

Annex 10 of ICAO contains procedures for air navigation services that apply to the operation of a SELCAL system. For a complete listing of the procedures it is recommended that one consult Volume II of Annex 10 Section 5.2.4. The following are a summary of most of the SELCAL radiotelephony procedures contained in annex:

## 3.1 Procedures for notification to aeronautical stations of SELCAL codes

- It is the responsibility of the aircraft operating agency to ensure that all aeronautical (ground) stations with which the aircraft would normally communicate during a particular flight know the SELCAL code associated with its radiotelephony call sign.
- When practicable, the aircraft operating agency should disseminate to all aeronautical stations concerned, at regular intervals, a list of SELCAL codes assigned to its aircraft or flights.
- The aircraft should
  - Include the SELCAL code in the flight plan submitted to the appropriate air traffic services unit; and
  - Ensure that the HF aeronautical station has the correct SELCAL code information by establishing communications temporarily with the HF aeronautical station while still within VHF coverage.

## 3.2 Procedures for preflight check

- The aircraft station should contact the appropriate aeronautical station and request a preflight SELCAL check and, if necessary, give its SELCAL code.
- When primary and secondary frequencies are assigned, a SELCAL check should normally be made first on the secondary frequency and then on the primary frequency. The aircraft station would then be ready for continued communication using the primary frequency.
- Should the preflight check reveal that either the ground or airborne SELCAL installation is inoperative; the aircraft should maintain a continuous listening watch on its subsequent flight until SELCAL again becomes available.

## 3.3 Procedures for establishment of communications

- When an aeronautical station initiates a call by SELCAL, the aircraft replies with its radio call sign, followed by the phrase, "Go Ahead."

## 3.4 En-route procedures

- Aircraft stations should ensure that the appropriate aeronautical station(s) are aware that SELCAL watch is being established or maintained.
- When so prescribed on the basis of regional air navigation agreements, calls for scheduled reports from aircraft may be initiated by an aeronautical station by means of SELCAL.
- Once SELCAL watch has been established by a particular aircraft station, aeronautical stations should employ SELCAL whenever they are required to contact the aircraft.
- In the event the SELCAL signal remains unanswered after two calls on the primary frequency and two calls on the secondary frequency, the aeronautical station should revert to voice calling.
- Stations in a network should keep each other immediately advised when malfunctioning occurs in a SELCAL installation on the ground or in the air. Likewise, the aircraft should ensure that the aeronautical stations concerned with its flight are immediately made aware of any malfunctioning of its SELCAL installation, and that voice calling is necessary.
- All stations should be advised when the SELCAL installation is again functioning normally.

### 3.5 SELCAL code assignments to aircraft

- In principal, the SELCAL code in the aircraft should be associated with the radiotelephony sign, i.e. where the flight number (service number) is employed as the radio call sign, the SELCAL code in the aircraft should be listed against the flight number. In all other cases, the SELCAL code in the aircraft should be listed against the aircraft registration.

**Note: Due to the limited number of SELCAL codes, the same code assignments to multiple aircraft should be expected. Therefore, the use of correct radiotelephony procedures is emphasized when establishing communications via SELCAL.**





# 4 System Administration

---

ASRI is the registrar for all worldwide SELCAL codes. These codes are issued to aircraft operators, verified annually, and decommissioned by ASRI on behalf of the International Civil Aviation Organization (ICAO). These codes can be used by aircraft in both VHF and HF radio communications operations. Due to the shortage of available codes, an accurate accounting of users and codes is very important. These services are provided at a minimal charge to aircraft operators. Codes are assigned to user aircraft on a directory basis. This assignment will normally be made by assigning individual codes or blocks of codes to air carrier organizations as requested with the maximum consideration being given to providing the minimum duplication of codes to aircraft which operate in the same areas of the world.

Because of the background noise level experienced on HF radio frequencies, aircrews usually prefer to turn down the audio level of their HF receiver until alerted via SELCAL of a message specifically intended for their aircraft. When the ground station operator wishes to communicate with an aircraft, he enters into the SELCAL encoder the 4-character code of that aircraft, which is usually included in its flight plan, and transmits that code over the assigned radio channel. All aircraft monitoring that channel receive the SELCAL broadcast, but only those (preferably only one) that have been programmed with that 4-character code will respond by sounding a chime or otherwise alerting the crew. The crew will then set their volume control higher to listen to the voice traffic and, using ICAO recommended radio procedures, assure that the message is intended for them.

As 32-tone codes are more prevalently assigned there is still a critical shortage of possible 4-letter codes, which has required re-use of the same code by more than one aircraft. Duplicate codes are usually assigned to aircraft operated in widely separated areas of the world, and usually do not have the same HF radio frequency assignment. However, there are occasions when two or more aircraft having the same code may be operating in the same general area, and will respond to the same transmission. Therefore, SELCAL should not be used as a substitute for proper voice identification procedures.

**Note: Due to the limited number of 4-letter SELCAL codes, the same code assignments to multiple aircraft should be expected. Therefore, the use of correct radiotelephony procedures is emphasized when establishing communications via SELCAL.**

It is important to remember that the SELCAL codes **do not transfer when an aircraft is sold**. They remain with the original registrant for use only in the areas of registration. SELCAL code utilization is verified annually. Please notify the SELCAL Registrar (ASRI Headquarters) if any of the following occur:

1. The aircraft is retired, sold, destroyed, or returned to a leasing/holding company
2. The registrant's main point of contact changes
3. The registrant's mailing address changes
4. Aircraft registration/tail number is modified
5. Aircraft communications links change (HF and/or VHF)
6. Aircraft type of code supported changes (12-Tone/16-tone/32-tone)
7. Areas of operation for an aircraft change

Certain information is required when an organization is applying for a SELCAL code(s). This following information is required when applying for SELCAL code(s):

1. Company name, address, name of contact, and contact information
2. Number of SELCAL codes requested
3. Aircraft registration/tail numbers
4. Aircraft communications links available (HF and/or VHF)
5. Type of code supported (12-Tone or 16-Tone)
6. Areas of operation (see Table 4-1)

Africa (AF)	North Africa (NF))
Central America (CA)	South America (SA)
Europe (EU)	South East Asia (SE)
Hawaii (HA)	South Africa (SF)
Middle East (ME)	South Pacific (SP)
North America (NA)	West Pacific (WP)

*Table: 4-1 SELCAL Areas of Operation*

To apply for a SELCAL code(s), please visit the ASRI website at [www.asri.aero](http://www.asri.aero)

## QUESTIONS

All questions regarding SELCAL codes should be directed to:

ASRI  
SELCAL Registrar  
180 Admiral Cochrane Drive, Suite 300  
Annapolis,  
MD 21401  
USA

Phone +1-410-266-6030

Fax +1-443-951-0349

[selcal@asri.aero](mailto:selcal@asri.aero)

[www.asri.aero](http://www.asri.aero)